



# DELTA-XERO

THE FUTURE IS SYSTEM RELIABILITY

## DX-1002-W

The DX modular housing arrangement offers a flexible and space conscious solution to integrate our innovative DXO Cartridge in to both new and existing systems. The Delta-Xero system can be configured up to 3 cartridges in parallel as a single unit in a compact and easily maintainable layout.

The unit can be supplied with a number of standard options to provide an effective fluid conditioning and monitoring package to suit the majority of systems. The flexibility of the unit allows tailoring to customer's specific requirements.



### DX1002-W

Drive Input	Electric or Pneumatic
Connection Ports	3/8" BSP In & Out
Flow Indicator	Visual
Max Reservoir Capacity	4000l @ 32cSt
Flow Rate	2 lpm @ 32cSt
Particulate Removal	From 0.1 $\mu$
Weight	15 kg
Measure	H 766 mm x D 261 mm x L 442 mm
Material	SS316
DXO Cartridge QTY	2

© 20 Delta-Xero All Rights Reserved. All information contained in this publication is indicative only and may be subject to change without prior notice.



## General Arrangement

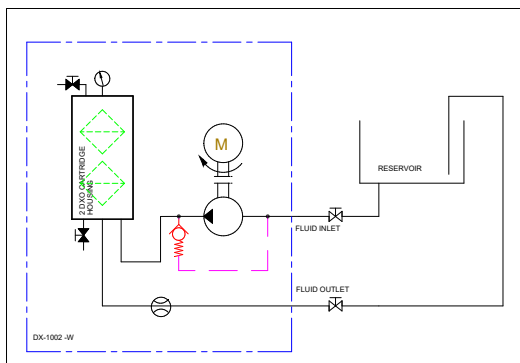
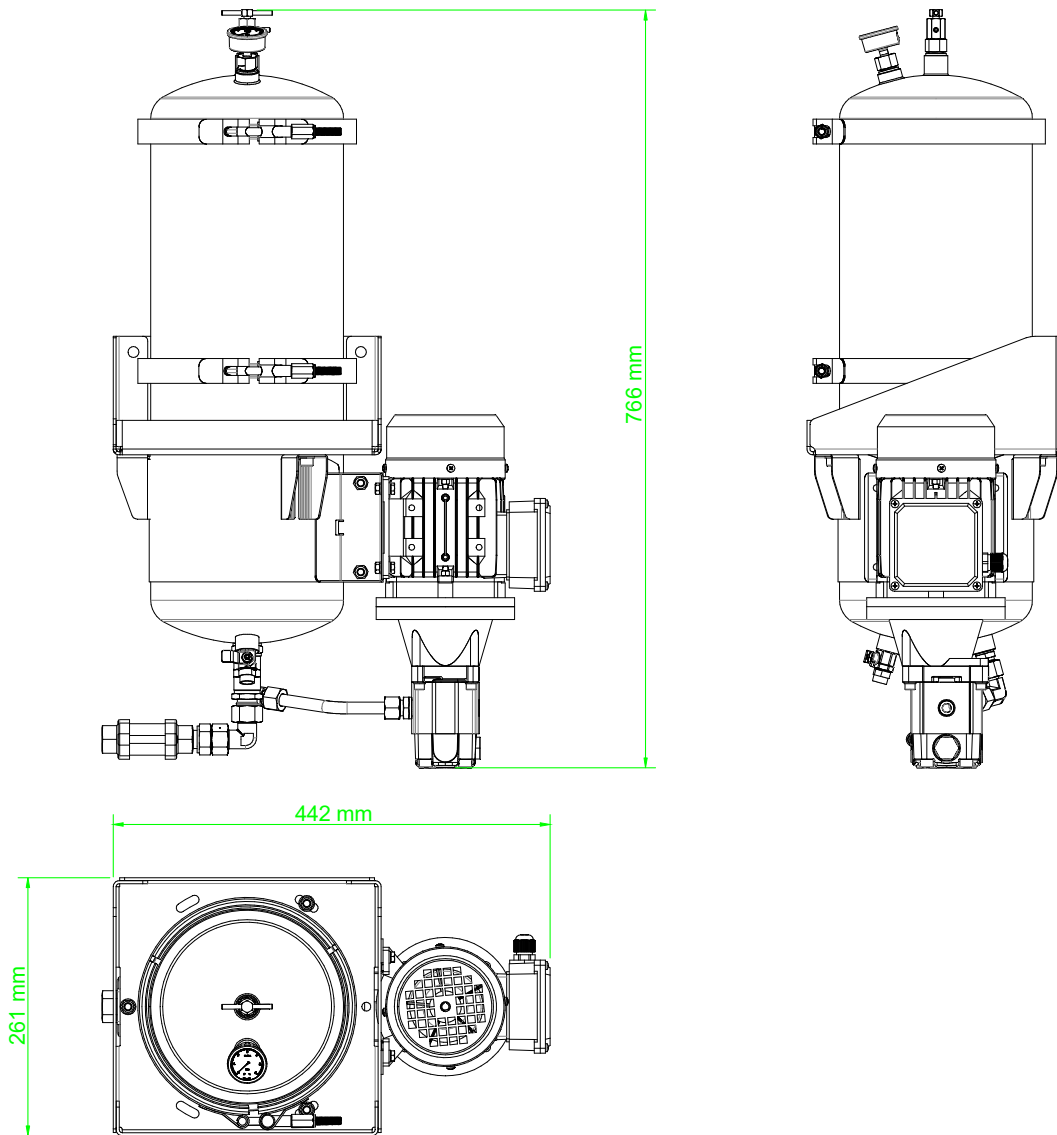

### DXO Cartridge

Contamination capacity:	1955 g, 0.1 micron
Water absorption, free and bound:	2600ml
Material Insert:	PP Cellulose mix

